

ST
 SECTION
 STEERING SYSTEM

A
 B
 C
 D
 E
 F
ST
 H
 I
 J
 K
 L
 M
 N
 O
 P

CONTENTS

SYSTEM DESCRIPTION	3
HEATED STEERING WHEEL	3
System Diagram	3
System Description	3
Component Parts Location	3
Component Description	4
WIRING DIAGRAM	5
HEATED STEERING WHEEL	5
Wiring Diagram	5
SYMPTOM DIAGNOSIS	8
NOISE, VIBRATION AND HARSHNESS (NVH) TROUBLESHOOTING	8
NVH Troubleshooting Chart	8
PRECAUTION	9
PRECAUTIONS	9
Precaution for Supplemental Restraint System (SRS) "AIR BAG" and "SEAT BELT PRE-TENSIONER"	9
Service Notice or Precautions	9
PREPARATION	10
PREPARATION	10
Special Service Tool	10
Commercial Service Tool	11
PERIODIC MAINTENANCE	12
POWER STEERING FLUID	12
Inspection	12
Draining	12
Refilling	12
STEERING WHEEL	14
Inspection	14
POWER STEERING OIL PUMP	16
Inspection	16
REMOVAL AND INSTALLATION	17
STEERING WHEEL	17
Removal and Installation	17
TILT MOTOR	18
Exploded View	18
Removal and Installation	18
TELESCOPIC MOTOR	20
Exploded View	20
Removal and Installation	20
STEERING COLUMN	22
Exploded View	22
Removal and Installation	23
STEERING GEAR AND LINKAGE	26
Exploded View	26
Removal and Installation	26
POWER STEERING OIL PUMP	28
Exploded View	28
Removal and Installation	28
HYDRAULIC LINE	29
Exploded View	29
Removal and Installation	30
UNIT DISASSEMBLY AND ASSEMBLY ...	31
STEERING COLUMN	31
Disassembly and Assembly	31
STEERING GEAR AND LINKAGE	33
Exploded View	33
Disassembly	33
Inspection	33
Assembly	34

POWER STEERING OIL PUMP	36	Steering Wheel	37
Disassembly and Assembly	36	Steering Angle	37
SERVICE DATA AND SPECIFICATIONS		Steering Column	37
(SDS)	37	Steering Gear	38
SERVICE DATA AND SPECIFICATIONS		Oil Pump	39
(SDS)	37	Steering Fluid	39

HEATED STEERING WHEEL

< SYSTEM DESCRIPTION >

SYSTEM DESCRIPTION

HEATED STEERING WHEEL

System Diagram

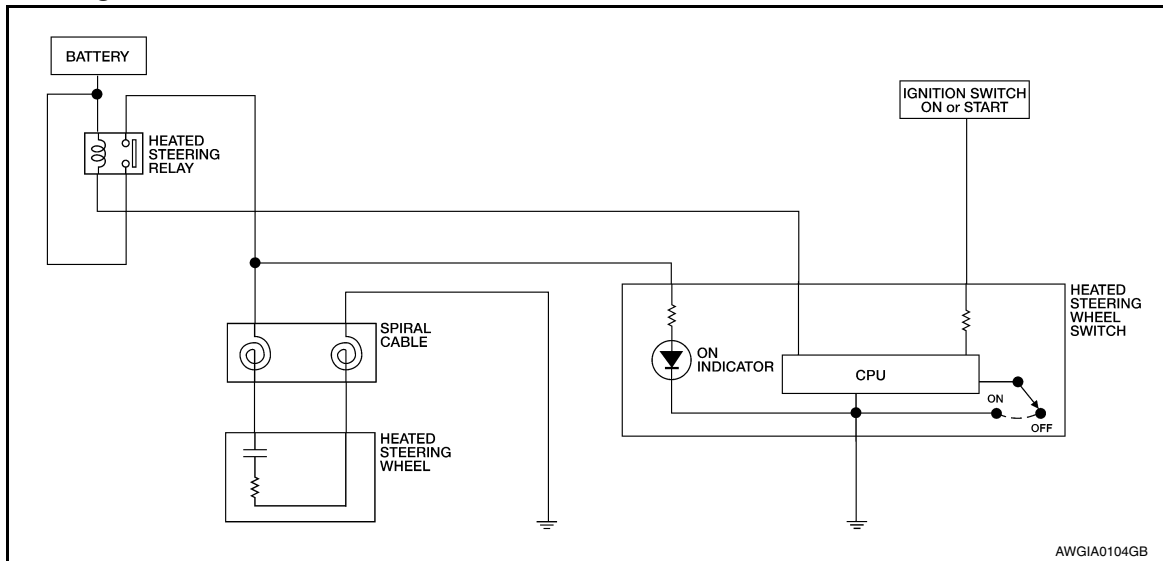

System Description

INFOID:000000009465759

The heated steering wheel switch controls the heated steering relay. When the switch is turned on, the relay is energized and the heated steering system will operate. The heated steering system will turn off when the steering wheel temperature reaches approximately 86° F (30° C). Heated steering system operation can also be canceled by pressing the heated steering wheel switch again.

NOTE:

If the surface temperature of the steering wheel is below 68° F (20° C), the system will heat the steering wheel and cycle off and on to maintain a temperature above 68° F (20° C). The indicator light will remain on as long as the system is on. Push the switch again to turn the heated steering wheel system off manually. The indicator light will go off.

Component Parts Location

INFOID:000000009465760

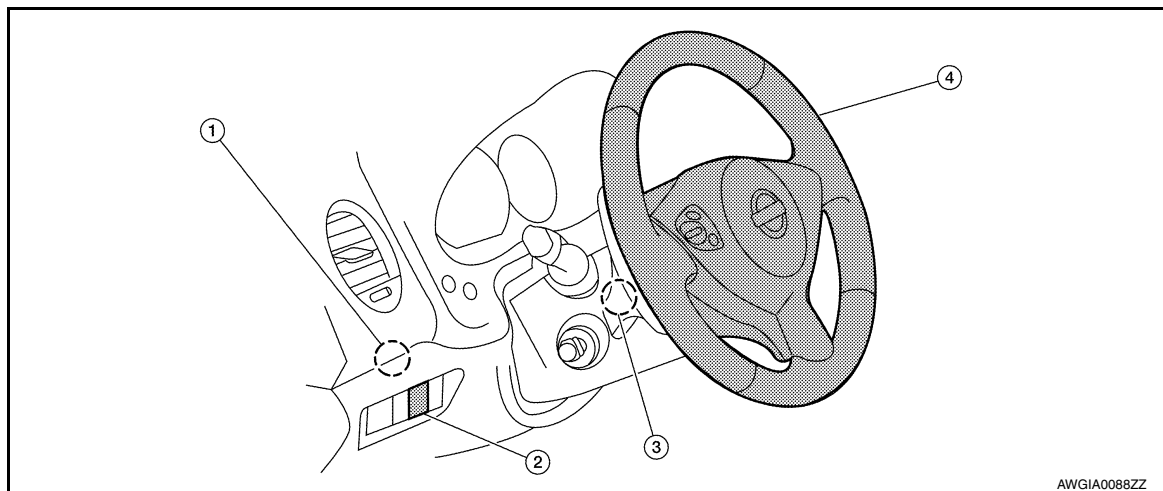

1. Heated steering relay M97
2. Heated steering wheel switch M96
3. Spiral cable M26
4. Heated steering wheel M114

HEATED STEERING WHEEL

< SYSTEM DESCRIPTION >

Component Description

INFOID:000000009465761

Heated steering wheel switch	<ul style="list-style-type: none">• Controls the heated steering relay and operates the heated steering wheel system.• Turns the indicator lamp ON when the system is activated.
Heated steering relay	<ul style="list-style-type: none">• Operates the heated steering system with the control signal from the heated steering wheel switch.
Heated steering wheel	<ul style="list-style-type: none">• Heats the heating element with the power supplied from the heated steering relay.

HEATED STEERING WHEEL

< WIRING DIAGRAM >

WIRING DIAGRAM

HEATED STEERING WHEEL

Wiring Diagram

INFOID:000000009465762

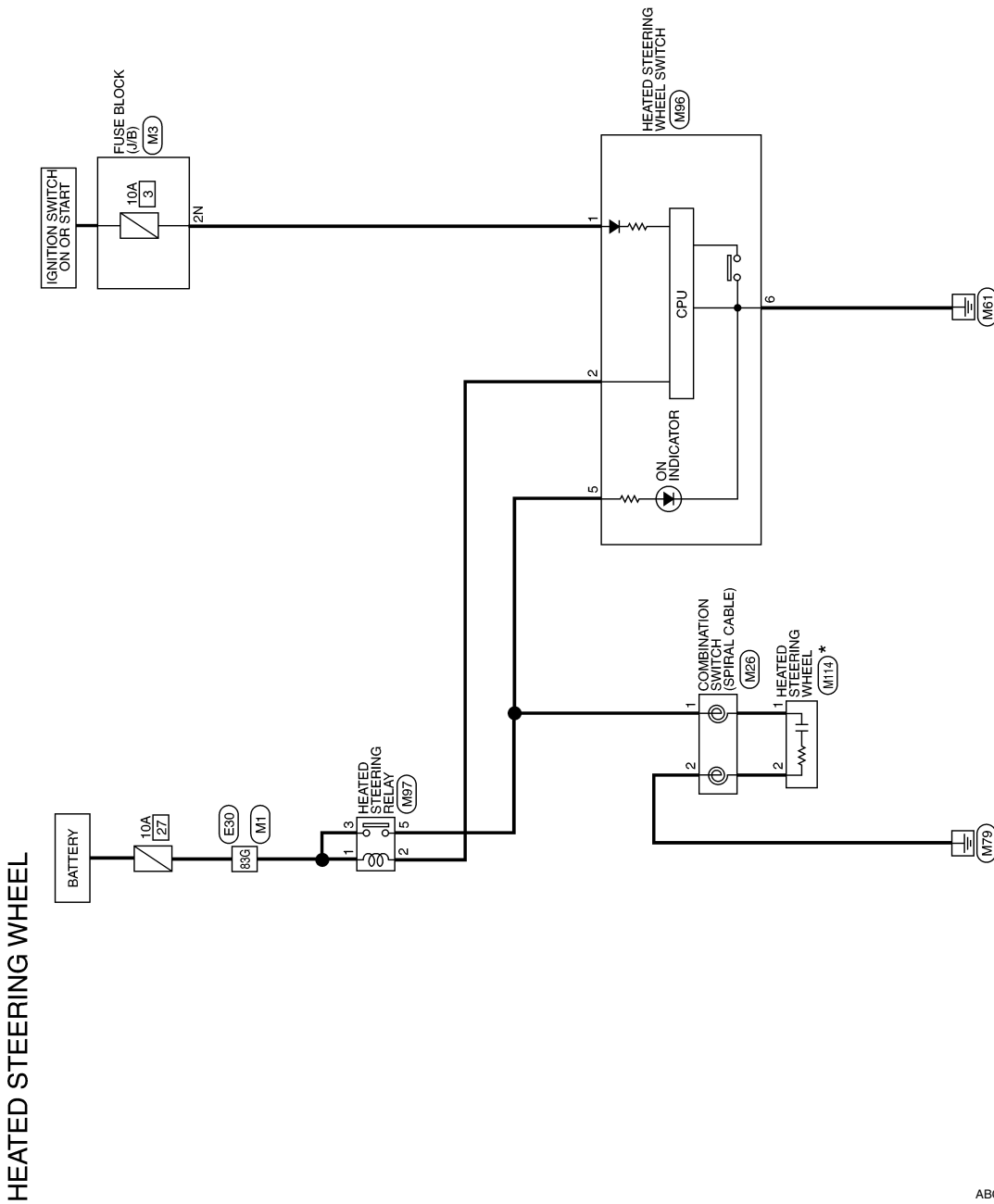

*: THIS CONNECTOR IS NOT SHOWN IN "HARNES LAYOUT" OF PG SECTION.

HEATED STEERING WHEEL

ABGWA0065GB

A
B
C
D
E
F
ST
H
I
J
K
L
M
N
O
P

HEATED STEERING WHEEL

< WIRING DIAGRAM >

HEATED STEERING WHEEL CONNECTORS

Connector No.	M1
Connector Name	WIRE TO WIRE
Connector Color	WHITE

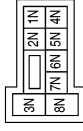
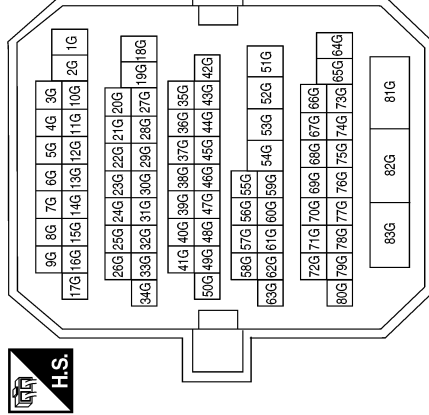

Terminal No.	Color of Wire	Signal Name
83G	B/W	-

Connector No.	M3
Connector Name	FUSE BLOCK (J/B)
Connector Color	WHITE

Terminal No.	Color of Wire	Signal Name
2N	G	-

Connector No.	M26
Connector Name	COMBINATION SWITCH (SPIRAL CABLE)
Connector Color	WHITE



Terminal No.	Color of Wire	Signal Name
1	BR	-
2	B	-

Connector No.	M96
Connector Name	HEATED STEERING WHEEL SWITCH
Connector Color	WHITE

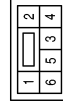

Terminal No.	Color of Wire	Signal Name
1	G	-
2	B/R	-
5	BR	-
6	B	-

Connector No.	M97
Connector Name	HEATED STEERING RELAY
Connector Color	BLUE



Terminal No.	Color of Wire	Signal Name
1	B/W	-
2	B/R	-
3	B/W	-
5	BR	-

HEATED STEERING WHEEL

< WIRING DIAGRAM >

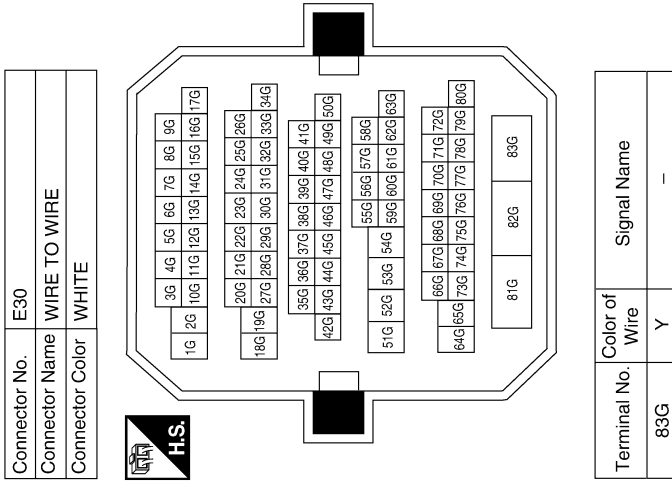

A
B
C
D
E
F
ST

H
I
J
K
L
M
N
O
P

ABGIA0010GB

NOISE, VIBRATION AND HARSHNESS (NVH) TROUBLESHOOTING

< SYMPTOM DIAGNOSIS >

SYMPTOM DIAGNOSIS

NOISE, VIBRATION AND HARSHNESS (NVH) TROUBLESHOOTING

NVH Troubleshooting Chart

INFOID:000000009465763

Use chart below to help you find the cause of the symptom. If necessary, repair or replace these parts.

Symptom	Steering	Possible cause and SUSPECTED PARTS														Reference page														
		Noise	Shake	Vibration	Shimmy	Shudder	Fluid level	Air in hydraulic system	Outer socket ball joint swinging force	Outer socket ball joint rotating torque	Outer socket ball joint end play	Steering fluid leakage	Steering wheel play	Steering gear rack sliding force	Drive belt looseness		Improper steering wheel	Improper installation or looseness of tilt lock lever	Mounting rubber deterioration	Steering column deformation or damage	Improper installation or looseness of steering column	Steering linkage looseness	WHEEL HUB	AXLE and SUSPENSION	TIRES	ROAD WHEEL	DRIVE SHAFT	BRAKES		
		x					x	x	x	x	x	x	x	x	x								x							ST-12
		x																											—	
		x																											ST-33	
		x																											ST-33	
		x																											ST-33	
		x																											ST-12	
		x																											ST-14	
		x																											ST-33	
		x																											EM-14. "Checking Drive Belts"	
																													—	
																													—	
																													ST-26	
																													ST-31	
																													ST-23	
																													ST-26	
																													Refer to FAX-4. "NVH Troubleshooting Chart"	
																													Refer to FSU-5. "NVH Troubleshooting Chart"	
																													Refer to WT-55. "NVH Troubleshooting Chart"	
																													Refer to WT-55. "NVH Troubleshooting Chart"	
																													Refer to FAX-4. "NVH Troubleshooting Chart"	
																													Refer to BR-6. "NVH Troubleshooting Chart"	

x: Applicable

PRECAUTIONS

< PRECAUTION >

PRECAUTION

PRECAUTIONS

Precaution for Supplemental Restraint System (SRS) "AIR BAG" and "SEAT BELT PRE-TENSIONER"

INFOID:000000009465764

The Supplemental Restraint System such as "AIR BAG" and "SEAT BELT PRE-TENSIONER", used along with a front seat belt, helps to reduce the risk or severity of injury to the driver and front passenger for certain types of collision. This system includes seat belt switch inputs and dual stage front air bag modules. The SRS system uses the seat belt switches to determine the front air bag deployment, and may only deploy one front air bag, depending on the severity of a collision and whether the front occupants are belted or unbelted. Information necessary to service the system safely is included in the SR and SB section of this Service Manual.

WARNING:

- To avoid rendering the SRS inoperative, which could increase the risk of personal injury or death in the event of a collision which would result in air bag inflation, all maintenance must be performed by an authorized NISSAN/INFINITI dealer.
- Improper maintenance, including incorrect removal and installation of the SRS, can lead to personal injury caused by unintentional activation of the system. For removal of Spiral Cable and Air Bag Module, see the SR section.
- Do not use electrical test equipment on any circuit related to the SRS unless instructed to in this Service Manual. SRS wiring harnesses can be identified by yellow and/or orange harnesses or harness connectors.

PRECAUTIONS WHEN USING POWER TOOLS (AIR OR ELECTRIC) AND HAMMERS

WARNING:

- When working near the Airbag Diagnosis Sensor Unit or other Airbag System sensors with the Ignition ON or engine running, DO NOT use air or electric power tools or strike near the sensor(s) with a hammer. Heavy vibration could activate the sensor(s) and deploy the air bag(s), possibly causing serious injury.
- When using air or electric power tools or hammers, always switch the Ignition OFF, disconnect the battery and wait at least 3 minutes before performing any service.

Service Notice or Precautions

INFOID:000000009465765

- In case of removing steering gear assembly, make the final tightening with grounded and unloaded vehicle condition, and then check wheel alignment.
- Observe the following precautions when disassembling.
 - Before disassembly, thoroughly clean the outside of the unit.
 - Disassembly should be done in a clean work area. It is important to prevent the internal parts from becoming contaminated by dirt or other foreign matter.
 - For easier and proper assembly, place disassembled parts in order on a parts rack.
 - Use nylon cloth or paper towels to clean the parts; common shop rags can leave lint that might interfere with their operation.
 - Do not reuse non-reusable parts.
 - Before assembling, apply the specified grease to the directed parts.

PREPARATION

< PREPARATION >

PREPARATION

PREPARATION

Special Service Tool

INFOID:000000009465766

The actual shapes of the tools may differ from those illustrated here.

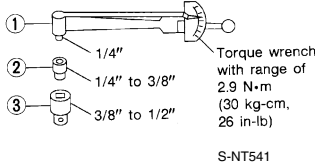
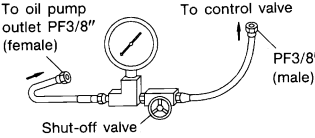
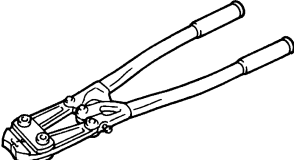
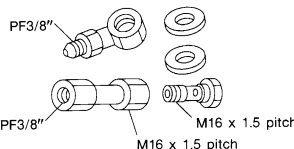
Tool number (TechMate No.) Tool name	Description
ST3127S000 (J-25765-A) Preload gauge 1. GG9103000 (J-25765-A) Torque wrench 2. HT62940000 (—) Socket adapter 3. HT62900000 (—) Socket adapter	Inspecting of rotating torque for ball joint and steering column  <p style="text-align: center;">S-NT541</p>
KV48103500 (J-26357) Pressure gauge	Measuring oil pump relief pressure  <p style="text-align: center;">S-NT547</p>
KV40107300 (—) Boot clamp crimping tool	Installing boot clamps  <p style="text-align: center;">ZZA1229D</p>
KV48102500 (J-33914) Pressure gauge adapter	Measuring oil pump relief pressure  <p style="text-align: center;">S-NT542</p>

PREPARATION

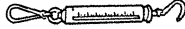
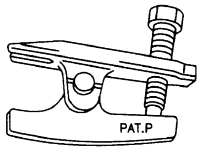

< PREPARATION >

Tool number (TechMate No.) Tool name	Description	A
— (J-44372) Spring gauge  LST024	Measuring steering wheel turning force, rack sliding force and ball joint swinging force	B C
HT72520000 (J-25730-A) Ball joint remover  PAT.P NT146	Removing ball joint	D E F

Commercial Service Tool

INFOID:000000009465767

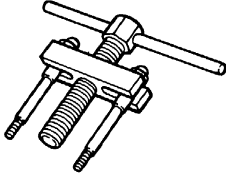
ST

Tool name	Description	
Steering wheel puller  ZZA0819D	Removing steering wheel	H I J
Power tool  PIIB1407E	Loosening nuts, screws and bolts	K L M N O P

POWER STEERING FLUID

< PERIODIC MAINTENANCE >

PERIODIC MAINTENANCE

POWER STEERING FLUID

Inspection

INFOID:000000009465768

FLUID LEVEL

- Check fluid level with engine stopped.
- Make sure that fluid level is between MIN and MAX.
- Fluid levels at HOT (A) and COLD (B) are different. Do not confuse them.

HOT (A) : Fluid temperature 50 - 80 °C (122- 176°F)

COLD (B) : Fluid temperature 0 - 30°C (32- 86°F)

CAUTION:

- The fluid level should not exceed the MAX line. Excessive fluid will cause fluid leakage from the cap.
- Do not reuse drained power steering fluid.
- Recommended fluid is Genuine Nissan PSF or equivalent.

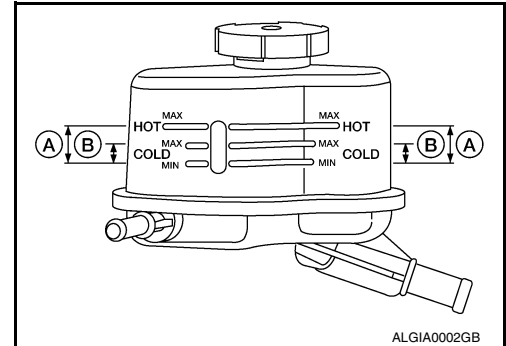

FLUID LEAKAGE

Check hydraulic connections for fluid leakage, cracks, damage, looseness, or wear.

1. Run engine until the fluid temperature reaches 50 - 80° C (122 - 176°F) in reservoir tank, and keep engine speed at idle.
2. Turn steering wheel several times from full left stop to full right stop.
3. Hold steering wheel at each lock position for five seconds and carefully, check for fluid leakage.

CAUTION:

Do not hold the steering wheel in a locked position for more than 10 seconds. (There is the possibility that oil pump may be damaged.)

4. If fluid leakage at connections is noticed, then loosen flare nut and then retighten. Do not overtighten connector as this can damage O-ring, copper sealing washers and connector.
5. If fluid leakage from oil pump is noticed, check oil pump. Refer to [ST-28. "Removal and Installation"](#).
6. Check steering gear boots for accumulation of fluid indicating leakage from steering gear.

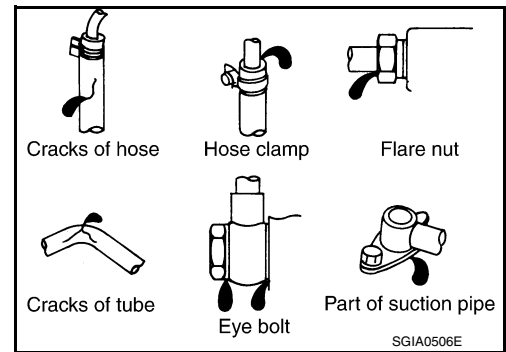

Draining

INFOID:000000009465769

1. Disconnect both high and low pressure lines from power steering gear.
2. Drain into a suitable container.

Refilling

INFOID:000000009465770

FILLING HYDRAULIC SYSTEM

1. Fill power steering reservoir while checking fluid level.
2. Bleed air from hydraulic system.
3. Check for fluid leaks.

AIR BLEEDING HYDRAULIC SYSTEM

If air bleeding is not complete, the following symptoms can be observed.

- Bubbles are created in reservoir tank.
- Clicking noise can be heard from oil pump.
- Excessive buzzing in the oil pump.

NOTE:

Fluid noise may occur in the steering gear or oil pump. This does not affect performance or durability of the system.

POWER STEERING FLUID

< PERIODIC MAINTENANCE >

1. Turn steering wheel several times from full left stop to full right stop with engine off.
CAUTION:
Do not allow the fluid level to drop below the MIN line.
2. Start engine and hold steering wheel at each lock position for three seconds at idle to check for fluid leakage.
3. Repeat step 2 above several times at approximately three second intervals.
CAUTION:
Do not hold the steering wheel in a locked position for more than 10 seconds. (There is the possibility that oil pump may be damaged.)
4. Check fluid for bubbles or white contamination.
5. Stop engine if bubbles or white contamination is present. Perform step 2 and 3 above after waiting until bubbles or white contamination disappear.
6. Stop the engine, and then check fluid level.

A

B

C

D

E

F

ST

H

I

J

K

L

M

N

O

P

STEERING WHEEL

< PERIODIC MAINTENANCE >

STEERING WHEEL

Inspection

INFOID:000000009465771

INSTALLATION CONDITION

- Check installation conditions of steering gear assembly, front suspension assembly, axle and steering column assembly.
- Check if movement exists when steering wheel is moved up and down, to the left and right and to the axial direction.

Steering wheel axial end play : Refer to [ST-37, "Steering Wheel"](#)

- Check steering gear assembly bolts and nut for looseness. Refer to [ST-26, "Exploded View"](#).

STEERING WHEEL PLAY

- Turn steering wheel so that front wheels come to the straight-ahead position. Start engine and lightly turn steering wheel to the left and right until front wheels start to move. Measure steering wheel movement on the outer circumference.

Steering wheel play : Refer to [ST-37, "Steering Wheel"](#)

- When the measurement value is outside the standard value, check backlash for each joint of steering column assembly and installation condition of steering gear assembly.

NEUTRAL POSITION OF STEERING WHEEL

- Make sure that steering gear assembly, steering column assembly and steering wheel are installed in the correct position.
- Perform neutral position inspection after wheel alignment. Refer to [FSU-6, "Inspection and Adjustment"](#).
- Set vehicle to the straight-ahead position and confirm steering wheel is in the neutral position.
- Loosen outer socket lock nut and turn inner socket to left and right equally to make fine adjustments if steering wheel is not in the neutral position.

STEERING WHEEL TURNING FORCE

1. Park vehicle on a level, dry surface and set parking brake.
2. Start engine.
3. Bring power steering fluid up to adequate operating temperature. Make sure the fluid temperature is approximately 50 - 80°C (122 - 176°F).
Tires need to be inflated to normal pressure.
4. Check steering wheel turning force using Tool when steering wheel has been turned 360 degrees from the neutral position.

Tool number : — (J-44372)

Steering wheel turning force : Refer to [ST-37, "Steering Wheel"](#)

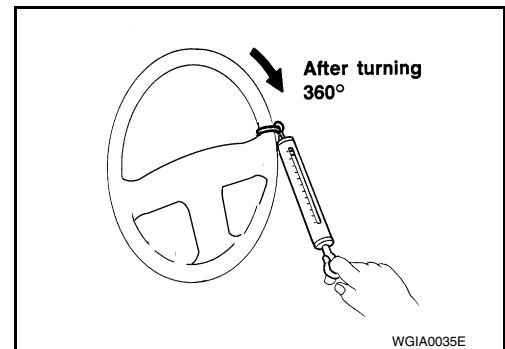

5. If steering wheel turning force is out of specification, check rack sliding force.

STEERING WHEEL

< PERIODIC MAINTENANCE >

- While pulling outer socket slowly in ± 11.5 mm (± 0.453 in) range from neutral position, make sure rack sliding force is within specification using Tool.

Tool number : — (J-44372)

Rack sliding force : Refer to [ST-38, "Steering Gear"](#)

- If rack sliding force is not within specification, replace steering gear assembly.
- If rack sliding force is OK, inspect steering column. Refer to [ST-23, "Removal and Installation"](#).

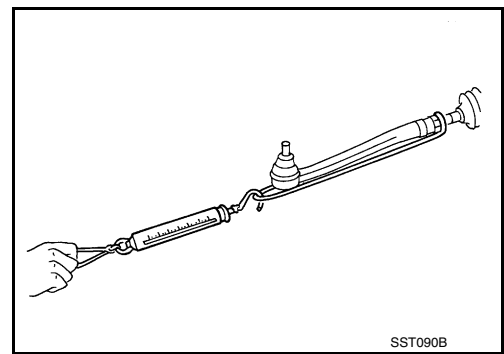

FRONT WHEEL TURNING ANGLE

- Check front wheel turning angle after toe-in inspection. Place front wheels on turning radius gauges and rear wheels on stands. Check the maximum inner and outer wheel turning angles for LH and RH road wheels.

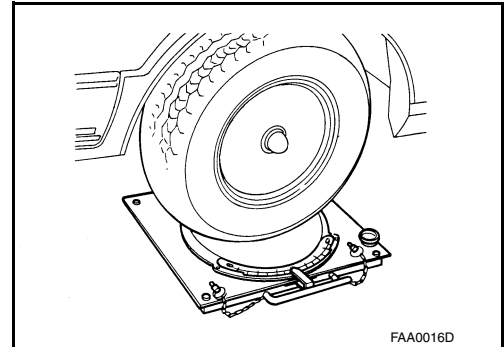

- With the engine at idle, turn steering wheel from full left stop to full right stop and measure the turning angles.

Inner wheel angle (A) : Refer to [ST-37, "Steering Angle"](#)

Outer wheel angle (B) : Refer to [ST-37, "Steering Angle"](#)

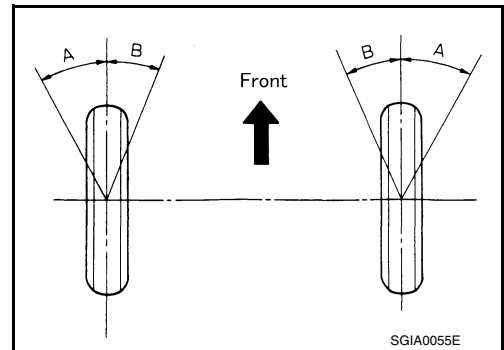

- Measure rack stroke in neutral position if angles are outside the specified value.

Rack stroke in neutral position (L) : Refer to [ST-38, "Steering Gear"](#)

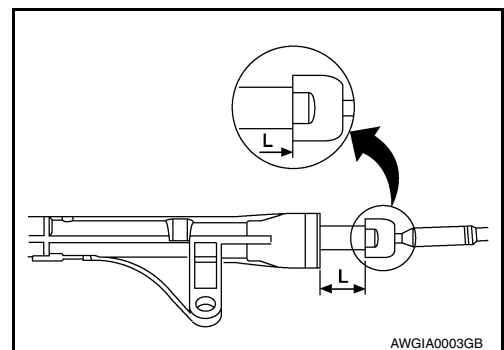

A
B
C
D
E
F
ST
H
I
J
K
L
M
N
O
P

POWER STEERING OIL PUMP

< PERIODIC MAINTENANCE >

POWER STEERING OIL PUMP

Inspection

INFOID:000000009465772

RELIEF OIL PRESSURE

CAUTION:

Make sure that belt tension is normal before starting the following procedure.

1. Connect the Tool between oil pump discharge connector and high-pressure hose. Bleed air from the hydraulic circuit while opening the shut-off valve fully. Refer to [ST-12, "Inspection"](#).

Tool numbers : KV48103500 (J-26357)
: KV48102500 (J-33914)

2. Start engine. Run engine until power steering fluid temperature reaches 50 - 80°C (122 - 176°F).

CAUTION:

- Leave the shut-off valve of the Tool fully open while starting and running engine. If engine is started with the shut-off valve closed, the hydraulic pressure in oil pump goes up to the relief pressure along with unusual increase of power steering fluid temperature.
- Be sure to keep hose clear of belts and other parts when engine is started.

3. Fully close the shut-off valve with engine at idle and measure the relief oil pressure.

Relief oil pressure : Refer to [ST-39, "Oil Pump"](#)

CAUTION:

Do not keep shut-off valve closed for 10 seconds or longer.

4. Open the shut-off valve slowly after measuring. Replace oil pump if the relief oil pressure is outside the standard.
5. After inspection, disconnect the Tool from hydraulic circuit, then add power steering fluid and perform air bleeding. Refer to [ST-12, "Inspection"](#).

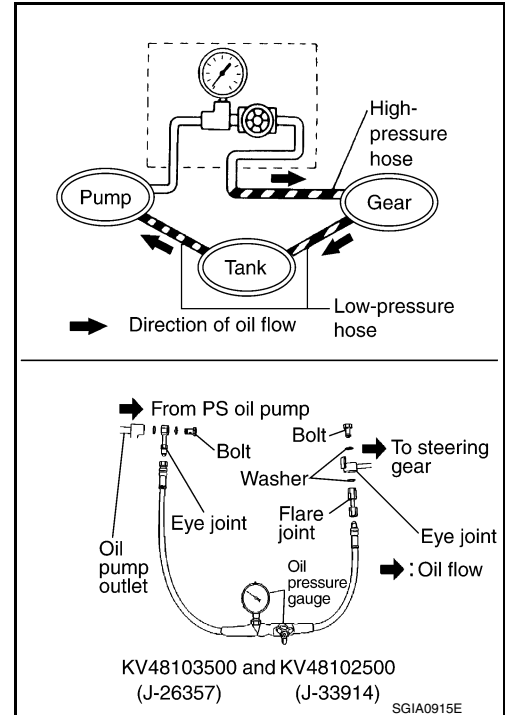

STEERING WHEEL

< REMOVAL AND INSTALLATION >

REMOVAL AND INSTALLATION

STEERING WHEEL

Removal and Installation

INFOID:000000009465773

REMOVAL

NOTE:

When removing spiral cable, use tape so that the case and rotating part keep aligned. This will prevent neutral position alignment procedure during spiral cable installation.

1. Set steering wheel to the straight-ahead position.
2. Remove driver air bag module. Refer to [SR-12, "Removal and Installation"](#).
3. Remove steering wheel lock nut after steering is locked.
4. Remove steering wheel using Tool (A).

Tool number (A) : ST27180001 (J-25726-A)

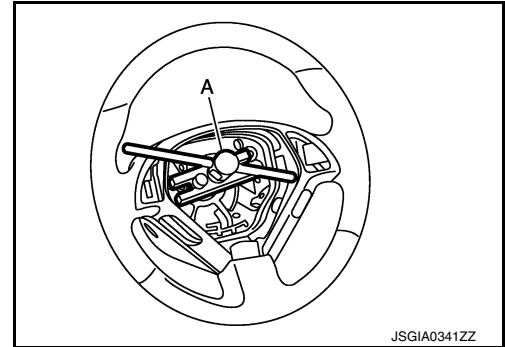

JSGIA0341ZZ

INSTALLATION

Installation is in the reverse order of removal.

CAUTION:

Do not rotate spiral cable freely or excessively when the steering wheel is removed. Doing so may cause spiral cable damage.

NOTE:

- Check the spiral cable neutral position after replacing or rotating spiral cable. Refer to [SR-15, "Removal and Installation"](#).
- Tighten the steering wheel lock nut to specification. Refer to [ST-22, "Exploded View"](#).

TILT MOTOR

< REMOVAL AND INSTALLATION >

TILT MOTOR

Exploded View

INFOID:000000009465774

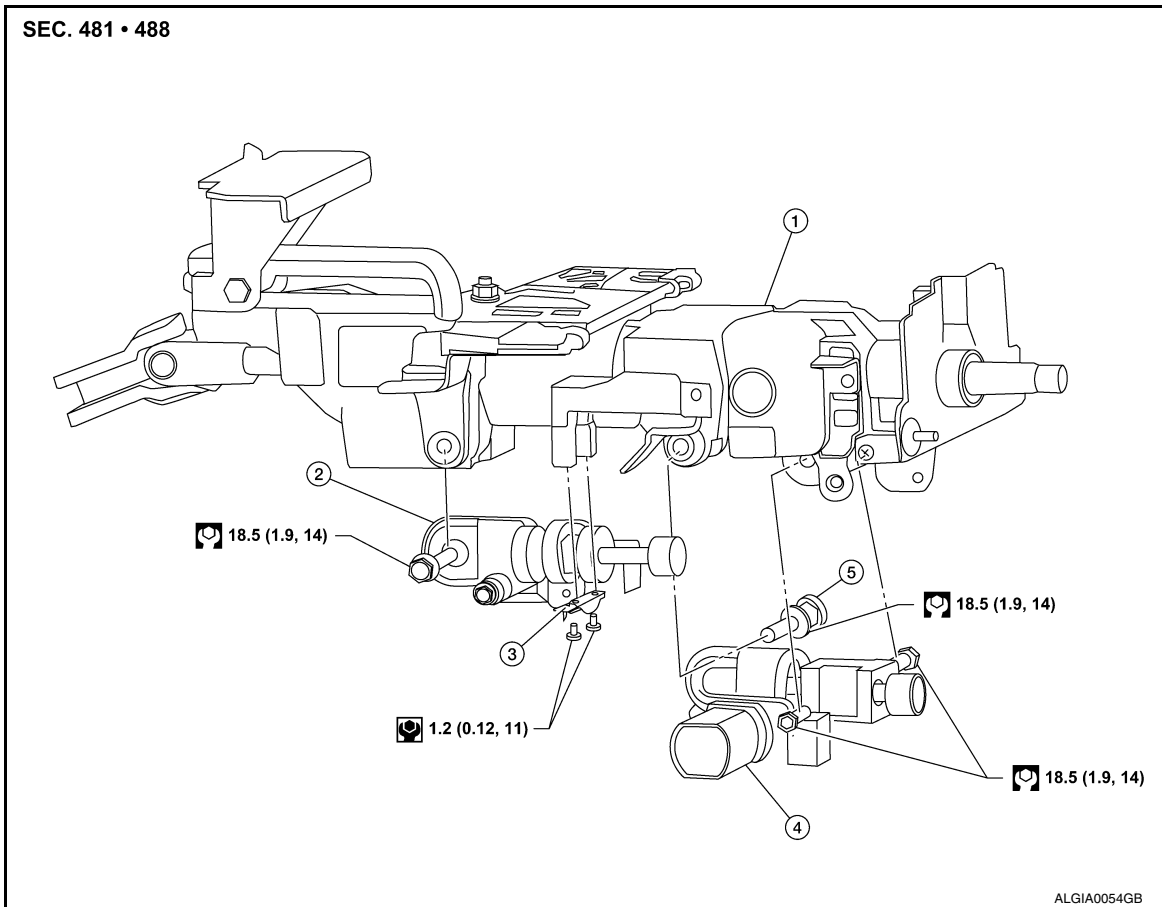

- | | | |
|-----------------------------|------------------------|---------------------------------|
| 1. Steering column assembly | 2. Telescope motor | 3. Telescope motor link bracket |
| 4. Tilt motor | 5. Tilt motor bolt cap | |

Removal and Installation

INFOID:000000009465775

REMOVAL

1. Remove instrument lower panel LH. Refer to [IP-19, "Removal and Installation"](#).
2. Remove lower knee protector (LH) bolts (A) and the lower knee protector (LH) (B).

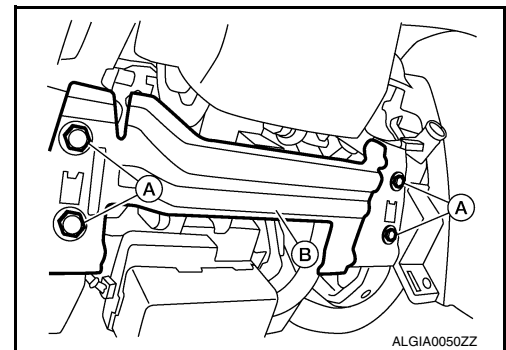

3. Telescope the steering wheel to the full out position and tilt to highest position.

NOTE:

If either function is inoperative you can do this manually prior to installation.

4. Remove the steering column covers. Refer to [IP-11, "Removal and Installation"](#).

NOTE:

TILT MOTOR

< REMOVAL AND INSTALLATION >

The tilt/telescope switch can remain attached to the side cover.

5. Remove the tilt motor as follows.
 1. Disconnect the harness connector (A) from the tilt motor.
 2. Remove the tilt motor link bolts (B).

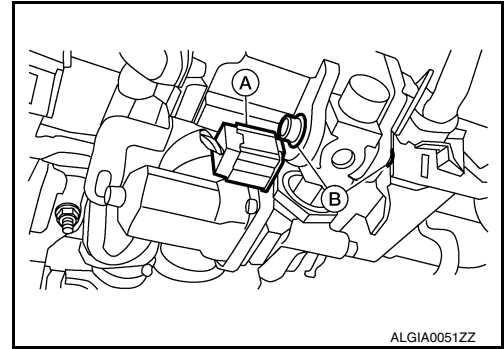

3. Remove the tilt motor bolt (A) from the RH side of column.
 4. Remove the tilt motor (B).

NOTE:

If the steering wheel could not be tilted to the highest position, manually tilt steering wheel to the highest position.

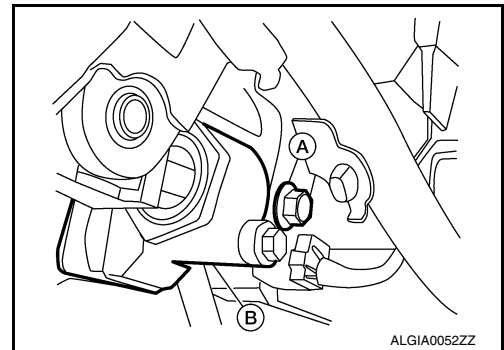

INSTALLATION

Installation is in the reverse order of removal.

NOTE:

- When installing the tilt motor link bolts, manually move steering wheel up and down to align the bolt holes.
- Inform customer that they will need to reset their Automatic Drive Positioner (ADP) settings.

TELESCOPIC MOTOR

< REMOVAL AND INSTALLATION >

TELESCOPIC MOTOR

Exploded View

INFOID:000000009465776

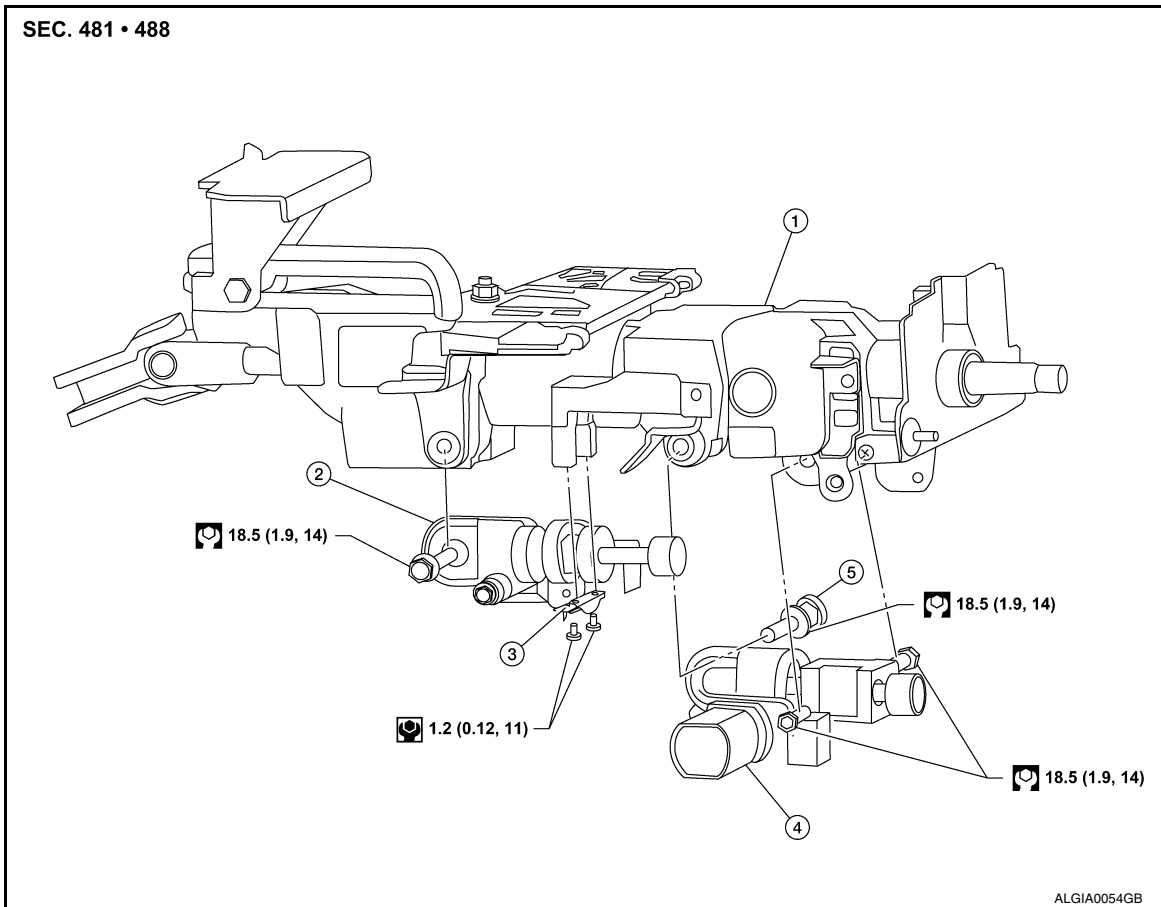

- | | | |
|-----------------------------|------------------------|---------------------------------|
| 1. Steering column assembly | 2. Telescope motor | 3. Telescope motor link bracket |
| 4. Tilt motor | 5. Tilt motor bolt cap | |

Removal and Installation

INFOID:000000009465777

REMOVAL

1. Remove instrument lower panel LH. Refer to [IP-19, "Removal and Installation"](#).
2. Remove lower knee protector (LH) bolts (A) and the lower knee protector (LH) (B).

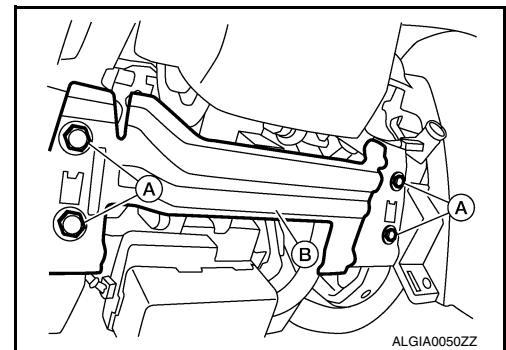

3. Telescope the steering wheel to the full out position and tilt to highest position.

NOTE:

If either function is inoperative you can do this manually prior to installation.

4. Remove the steering column covers. Refer to [IP-11, "Removal and Installation"](#).

NOTE:

TELESCOPIC MOTOR

< REMOVAL AND INSTALLATION >

The tilt/telescope switch can remain attached to the side cover.

5. Remove telescope motor as follows.
 1. Disconnect the harness connector (A) from the telescope motor.
 2. Remove the two telescope motor link screws (B) and telescope motor link bracket.
 3. Remove telescope motor bolt (C).
 4. Remove the telescope motor (D).

NOTE:

If the steering wheel could not be telescoped to full out position manually pull steering wheel to the full out position.

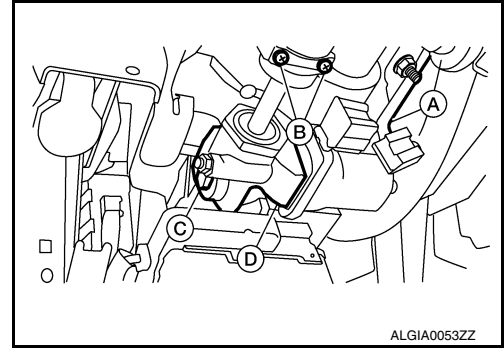

INSTALLATION

Installation is in the reverse order of removal.

NOTE:

- Adjust the telescope motor link to full out position and adjust as needed to fit into proper installed position.
- Inform customer that they will need to reset their Automatic Drive Positioner (ADP) settings.

A
B
C
D
E
F
ST
H
I
J
K
L
M
N
O
P

STEERING COLUMN

< REMOVAL AND INSTALLATION >

STEERING COLUMN

Exploded View

INFOID:000000009465778

Without Electric Motor

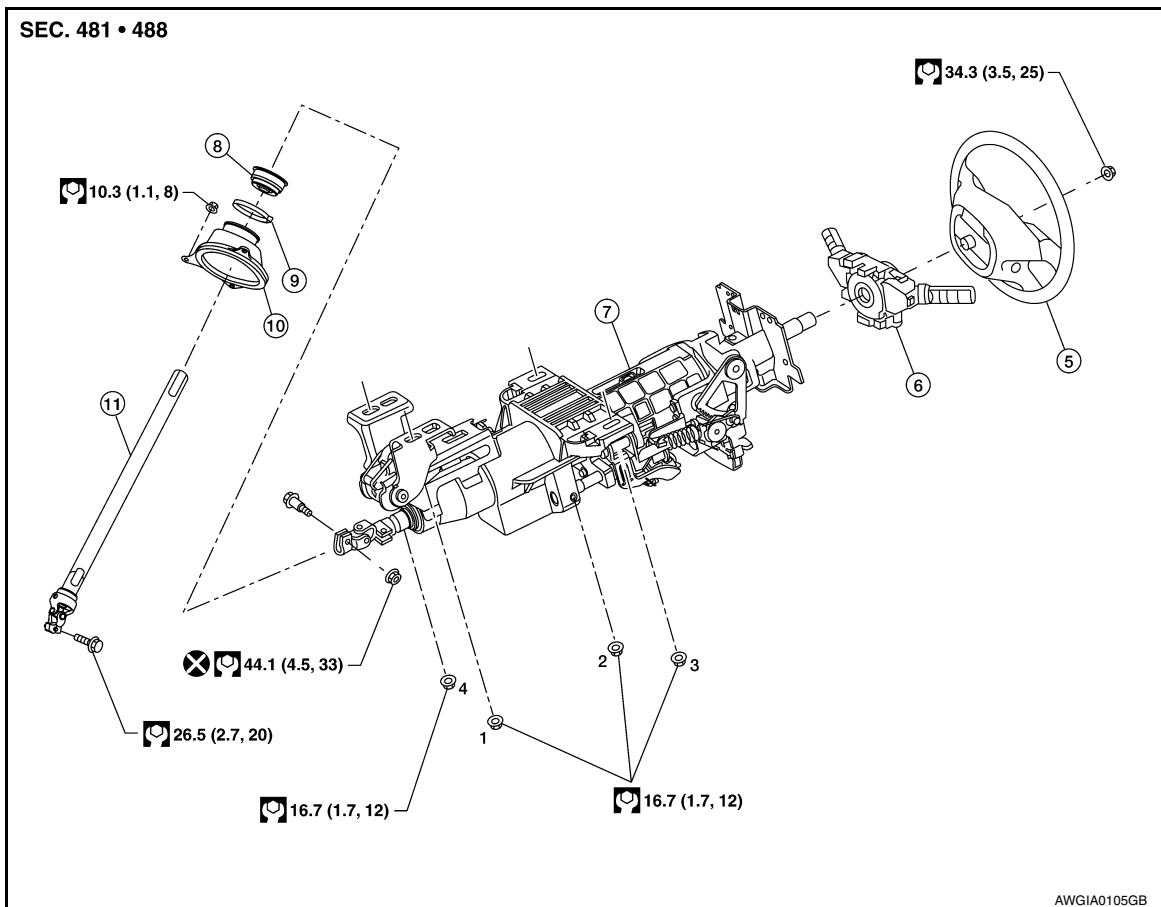

- | | | |
|--|--------------------------|--|
| 1-4. Steering column assembly nut tightening order | 5. Steering wheel | 6. Combination switch and spiral cable |
| 7. Steering column assembly | 8. Hole cover seal | 9. Herbie clip |
| 10. Hole cover | 11. Lower shaft assembly | |

STEERING COLUMN

< REMOVAL AND INSTALLATION >

With Electric Motor

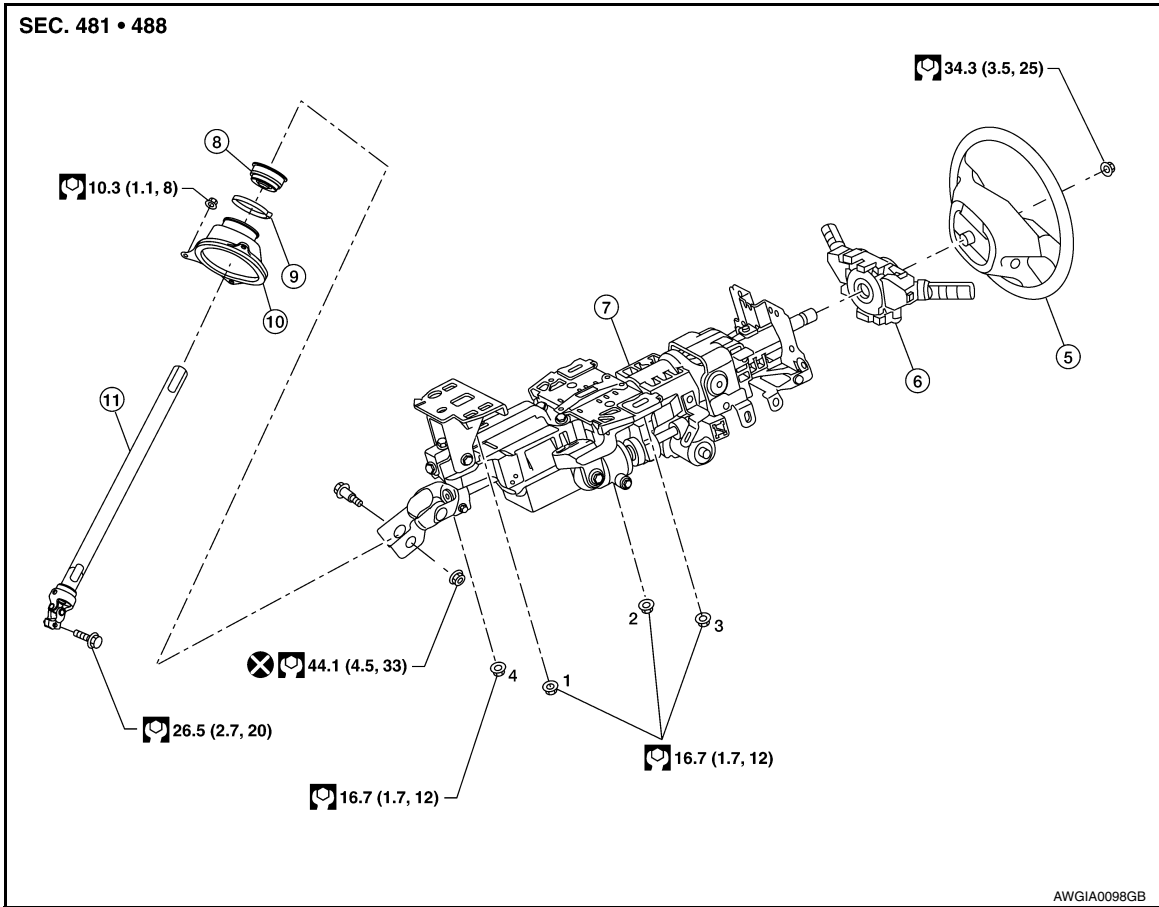

- | | | |
|--|--------------------------|--|
| 1-4. Steering column assembly nut tightening order | 5. Steering wheel | 6. Combination switch and spiral cable |
| 7. Steering column assembly | 8. Hole cover seal | 9. Herbie clip |
| 10. Hole cover | 11. Lower shaft assembly | |

Removal and Installation

INFOID:000000009465779

REMOVAL

Hole Cover Seal, Hole Cover and Lower Shaft Assembly

1. Set wheels to the straight-ahead position.
2. Remove lower side bolt (A) of lower shaft assembly (1).
 - Steering gear (2)

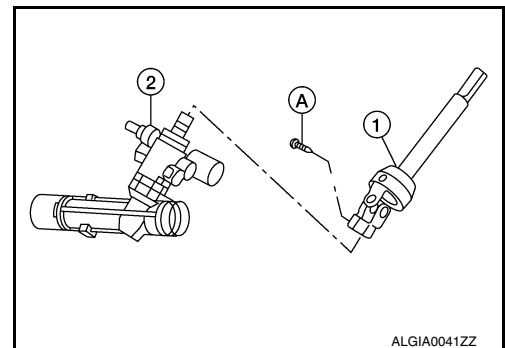

3. Remove the instrument lower panel LH. Refer to [IP-19. "Removal and Installation"](#).

STEERING COLUMN

< REMOVAL AND INSTALLATION >

4. Remove bolt (A) and nut (B) of column upper joint (2), then remove lower shaft assembly (1).

CAUTION:

Do not reuse column upper joint nut.

5. Loosen herbie clip, then remove hole cover seal from hole cover.
6. Remove nuts of hole cover, and then remove clamp and hole cover from dash panel.

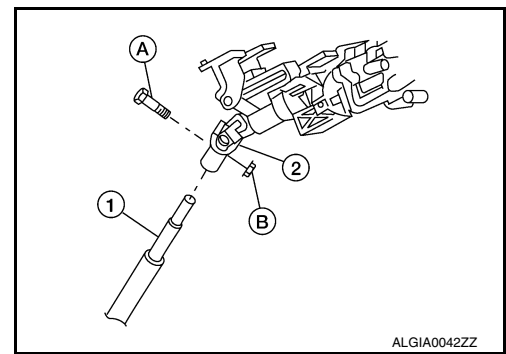

Steering Column Assembly

1. Set wheels to the straight-ahead position.
2. Remove instrument side finisher (LH). Refer to [IP-10, "Exploded View"](#).
3. Remove instrument lower panel LH. Refer to [IP-19, "Removal and Installation"](#).
4. Remove lower knee protector (LH) bolts (←), then remove lower knee protector (LH) (1). Refer to [IP-10, "Exploded View"](#).
5. Remove steering column upper and lower covers. Refer to [IP-10, "Exploded View"](#).
6. Remove combination switch and spiral cable. Refer to [SR-15, "Removal and Installation"](#).
7. Disconnect each switch harness connector installed to steering column assembly, and then disconnect harness clips from steering column assembly.

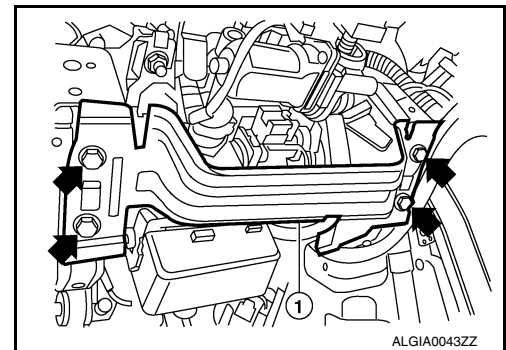

8. Remove bolt (A) and nut (B) of column upper joint (2).
 - Lower shaft assembly (1)

CAUTION:

Do not reuse column upper joint nut.

9. Remove steering column assembly nuts, then remove steering column assembly.

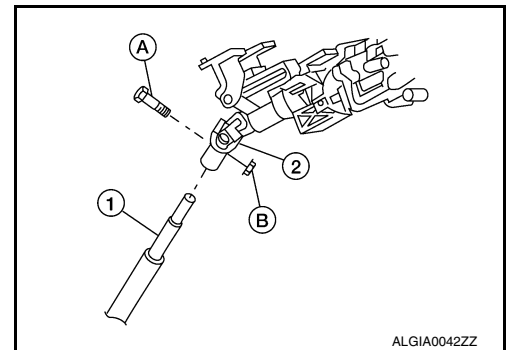

INSPECTION AFTER REMOVAL

Hole Cover Seal, Hole Cover and Lower Shaft Assembly

Check each part of hole cover seal, hole cover and steering column and lower shaft assembly for damage or other malfunctions. Replace if necessary.

Steering Column Assembly

- Check each part of steering column assembly for damage or other malfunctions. Replace entire steering column assembly if any parts are damaged.
- Measure the length (L) as shown if vehicle has been involved in a minor collision. Replace steering column assembly if outside the specifications.

Steering column length (L) : Refer to [ST-37, "Steering Column"](#)

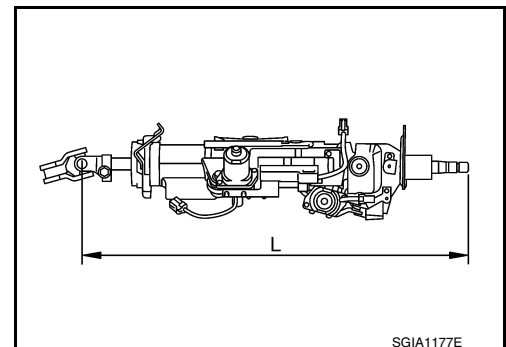

STEERING COLUMN

< REMOVAL AND INSTALLATION >

- Measure steering column rotating torque using Tool. Replace steering column assembly if outside the standard.

Tool number : ST3127S000 (J-25765-A)

Rotating torque : Refer to [ST-37, "Steering Column"](#)

- Check tilt and telescopic mechanism operating range (L^1), (L^2) as shown.

Tilt operating range (L^1) : Refer to [ST-37, "Steering Column"](#)

Telescopic operating range (L^2) : Refer to [ST-37, "Steering Column"](#)

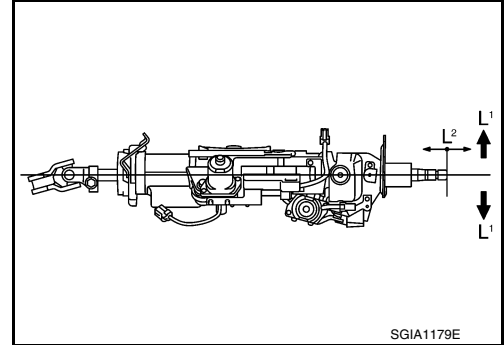

SGIA1179E

INSTALLATION

Hole Cover Seal, Hole Cover and Lower Shaft Assembly

Installation is in the reverse order of removal.

- When installing lower shaft assembly to steering gear assembly, follow the procedure listed below.
- Set rack of steering gear in the neutral position.

NOTE:

To get the neutral position of rack, turn gear sub-assembly and measure the distance of inner socket, and then measure the intermediate position of the distance.

- Align rear cover cap projection (A) with the marking position (B) of gear housing assembly.
- Install slit part of lower shaft assembly (C) aligning with the projection (A) of rear cover cap (1). Make sure that the slit part of lower shaft assembly (C) is aligned with both the projection (A) of rear cover cap (1) and the marking position (B) of gear housing assembly.

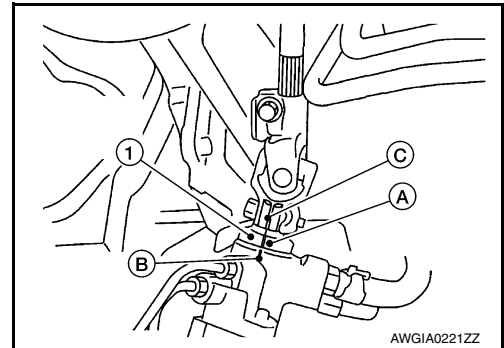

AWGIA0221ZZ

Steering Column Assembly

Installation is in the reverse order of removal.

STEERING GEAR AND LINKAGE

< REMOVAL AND INSTALLATION >

STEERING GEAR AND LINKAGE

Exploded View

INFOID:000000009465780

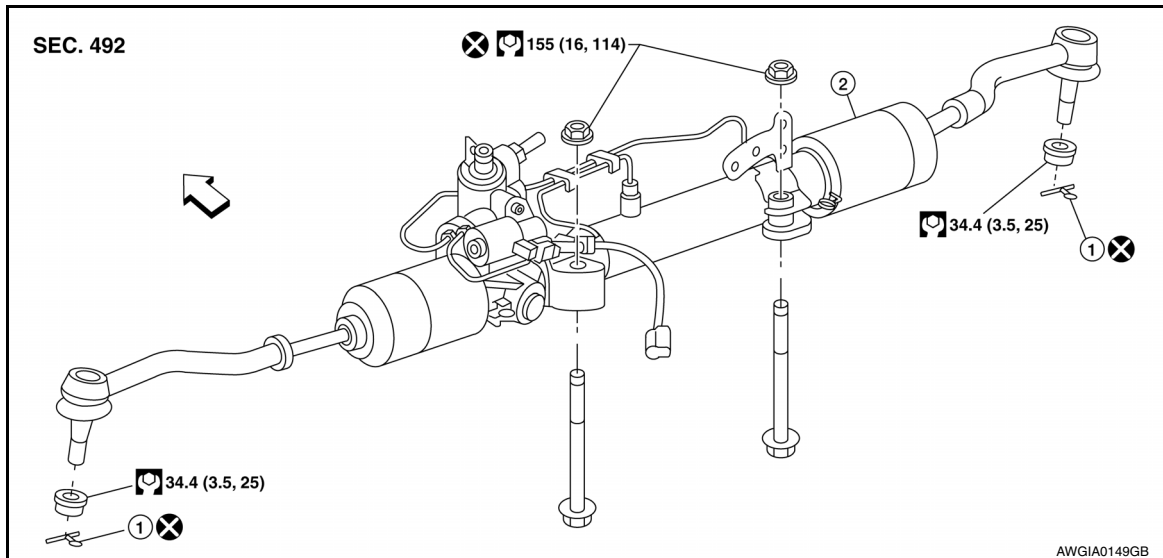

1. Cotter pin

2. Steering gear assembly

← Front

Removal and Installation

INFOID:000000009465781

NOTE:

When removing components such as hoses, tubes/lines, etc., cap or plug openings to prevent fluid from spilling.

REMOVAL

1. Remove front wheel and tire using power tool. Refer to [WT-60, "Adjustment"](#).
2. Drain power steering fluid. Refer to [ST-12, "Draining"](#).
3. Disconnect front stabilizer connecting rods from front stabilizer and reposition front stabilizer. Refer to [FSU-11, "Removal and Installation"](#).
4. Remove steering outer socket cotter pins (1), and then loosen the nuts.
5. Remove steering outer sockets (2) from steering knuckles (3) so as not to damage ball joint boots (4) using Tool.

CAUTION:

Temporarily tighten the nut to prevent damage to threads and to prevent the Tool from suddenly coming off.

Tool number : HT72520000 (J-25730-A)

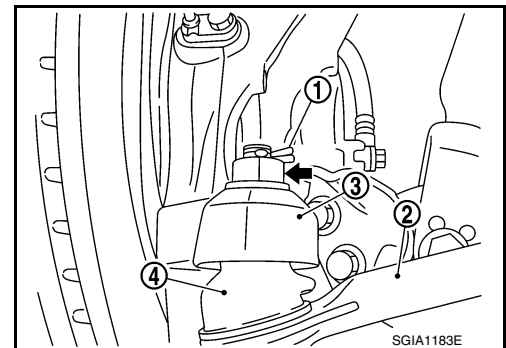

STEERING GEAR AND LINKAGE

< REMOVAL AND INSTALLATION >

6. Remove side bolt (A) of lower shaft assembly (1) and disconnect lower shaft assembly.
 - Steering gear assembly (2)
7. Remove front exhaust tube. Refer to [EX-5. "Removal and Installation"](#).
8. Disconnect the harness connector from the SSPS valve. Refer to [ST-33. "Exploded View"](#).
9. Disconnect high and low pressure piping from steering gear assembly. Refer to [ST-29. "Exploded View"](#)
10. Remove steering hydraulic piping bracket from front suspension member.
11. Remove bolts and nuts of steering gear assembly, and then remove steering gear assembly from vehicle.

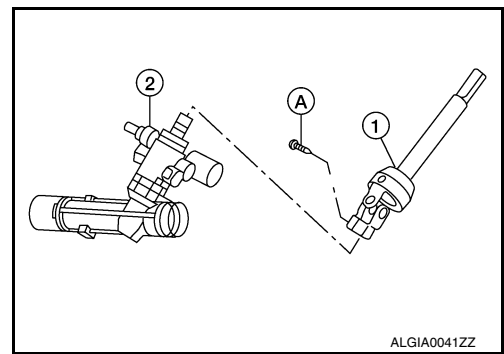

INSPECTION AFTER REMOVAL

Check for fluid leaks or damage to steering gear assembly. If any exist, replace steering gear assembly.

INSTALLATION

Installation is in the reverse order of removal.

CAUTION:

- Do not reuse cotter pins.
- Do not reuse steering gear assembly nuts.
- When installing lower shaft assembly to steering gear assembly, follow the procedure listed below.
- Set rack of steering gear in the neutral position.

NOTE:

- To get the neutral position of rack, turn gear sub-assembly and measure the distance of inner socket, and then measure the intermediate position of the distance.
- Align rear cover cap projection (A) with the marking position (B) of gear housing assembly.
 - Install slit part of lower shaft assembly (C) aligning with the projection (A) of rear cover cap (1). Make sure that the slit part of lower shaft assembly (C) is aligned with both the projection (A) of rear cover cap (1) and the marking position (B) of gear housing assembly.
 - Connect the high and low pressure piping to the steering gear. Tighten to specification. Refer to [ST-30. "Removal and Installation"](#).
 - After installation, bleed air from the steering hydraulic system. Refer to [ST-12. "Inspection"](#).
 - Check wheel alignment. Refer to [FSU-6. "Inspection and Adjustment"](#).

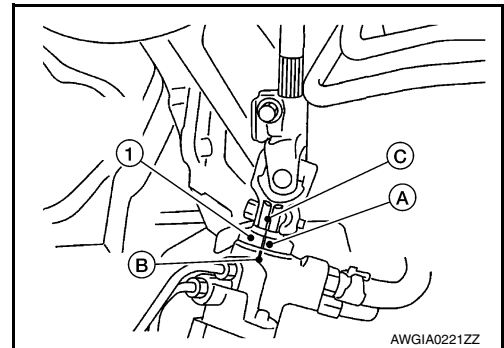

INSPECTION AFTER INSTALLATION

Make sure that steering wheel operates smoothly by turning several times from full left stop to full right stop.

POWER STEERING OIL PUMP

< REMOVAL AND INSTALLATION >

POWER STEERING OIL PUMP

Exploded View

INFOID:000000009465782

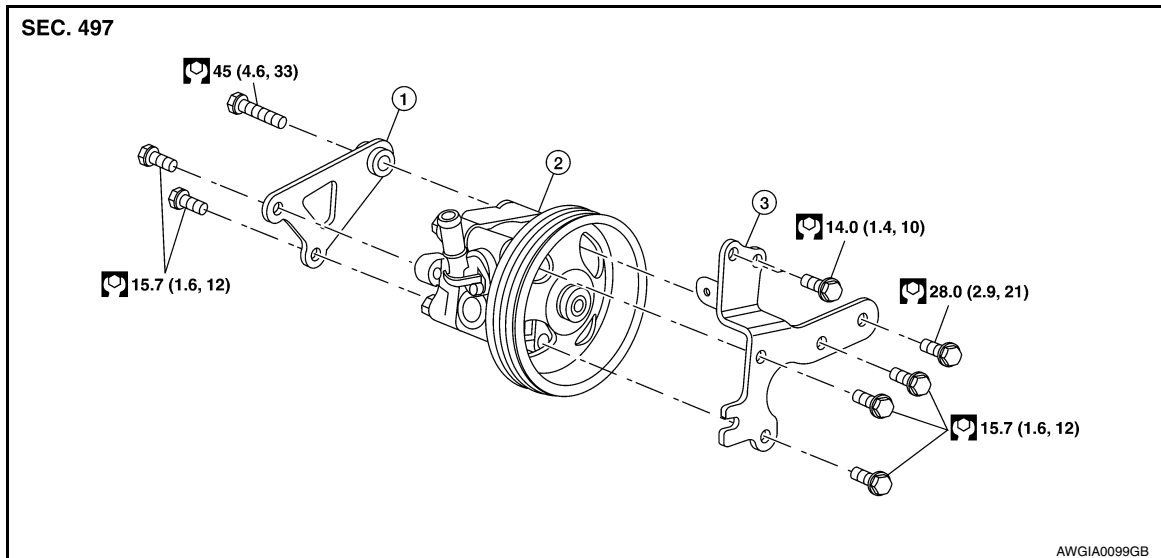

1. Rear bracket
2. Power steering oil pump assembly
3. Front bracket

Removal and Installation

INFOID:000000009465783

NOTE:

When removing components such as hoses, tubes/lines, etc., cap or plug openings to prevent fluid from spilling.

REMOVAL

1. Remove front wheel and tire (RH) using power tool. Refer to [WT-60, "Adjustment"](#).
2. Remove front fender protector side cover. Refer to [EXT-23, "Exploded View"](#).
3. Remove hood ledge cover (RH).
4. Drain power steering fluid. Refer to [ST-12, "Draining"](#).
5. Disconnect the power steering pressure sensor harness connector at the high pressure pipe. Refer to [ST-29, "Exploded View"](#).
6. Disconnect high pressure piping and suction hose from power steering oil pump. Refer to [ST-29, "Exploded View"](#).
7. Loosen drive belt. Refer to [EM-14, "Removal and Installation"](#).
8. Remove drive belt from power steering oil pump pulley.
9. Remove power steering oil pump bolts, and then remove power steering oil pump.

INSTALLATION

Installation is in the reverse order of removal.

- When installing power steering oil pump, install all bolts by hand initially, then tighten bolts to specification.
- Perform the following procedures after installing.
 - Check belt tension. Refer to [EM-14, "Checking Drive Belts"](#).
 - Bleed air from power steering system. Refer to [ST-12, "Refilling"](#).

HYDRAULIC LINE

< REMOVAL AND INSTALLATION >

HYDRAULIC LINE

Exploded View

INFOID:000000009465784

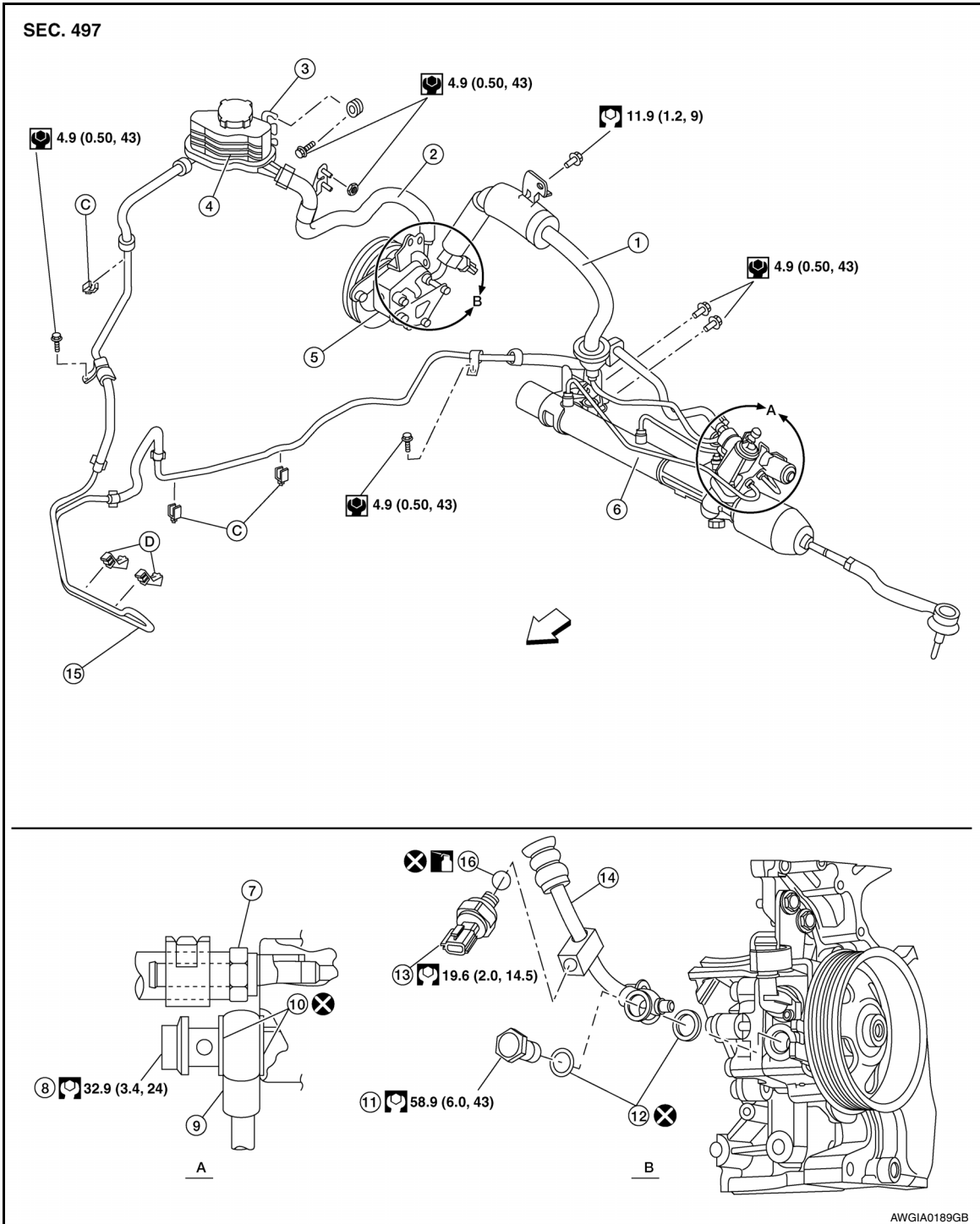

- | | | |
|------------------------------------|-------------------------------|---------------------------------|
| 1. High pressure hose | 2. Suction hose | 3. Reservoir tank bracket |
| 4. Reservoir tank | 5. Oil pump assembly | 6. Steering gear assembly |
| 7. Low pressure piping | 8. Eye bolt | 9. High pressure piping |
| 10. Copper sealing washers | 11. Eye bolt | 12. Copper sealing washers |
| 13. Power steering pressure sensor | 14. High pressure hose piping | 15. Power steering fluid cooler |

HYDRAULIC LINE

< REMOVAL AND INSTALLATION >

16. O-ring

↩ Front

A. View A

B. View B

Removal and Installation

INFOID:000000009465785

CAUTION:

- Securely insert harness connector to pressure sensor.
- Do not reuse O-rings or copper sealing washers.

NOTE:

When removing components such as hoses, tubes/lines, etc., cap or plug openings to prevent fluid from spilling.

REMOVAL

Refer to [ST-29. "Exploded View"](#) for removal.

INSTALLATION

- Insert hose securely until it contacts tube spool.

CAUTION:

Do not use lubricant on hose or fitting.

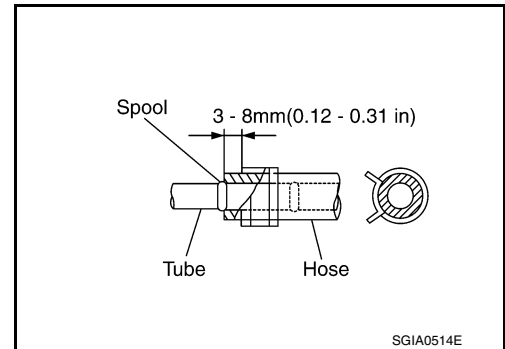

- Install eye-bolt (1), copper sealing washers (2) and eye-joint (assembled to high-pressure hose) (4) onto oil pump assembly (3), and temporarily tighten the eye-bolt, then tighten it to the specified torque.

CAUTION:

Do not reuse copper sealing washers.

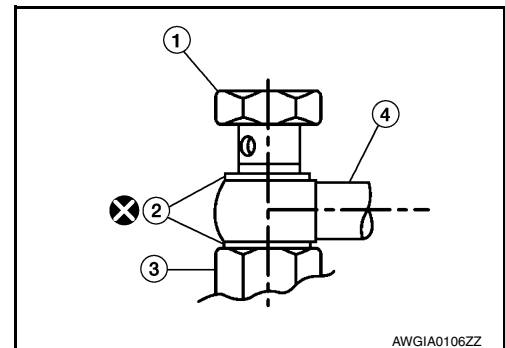

STEERING COLUMN

< UNIT DISASSEMBLY AND ASSEMBLY >

UNIT DISASSEMBLY AND ASSEMBLY

STEERING COLUMN

Disassembly and Assembly

INFOID:000000009465786

The steering column assembly without electric motor is not serviceable and must be replaced as an assembly.

With Electric Motor

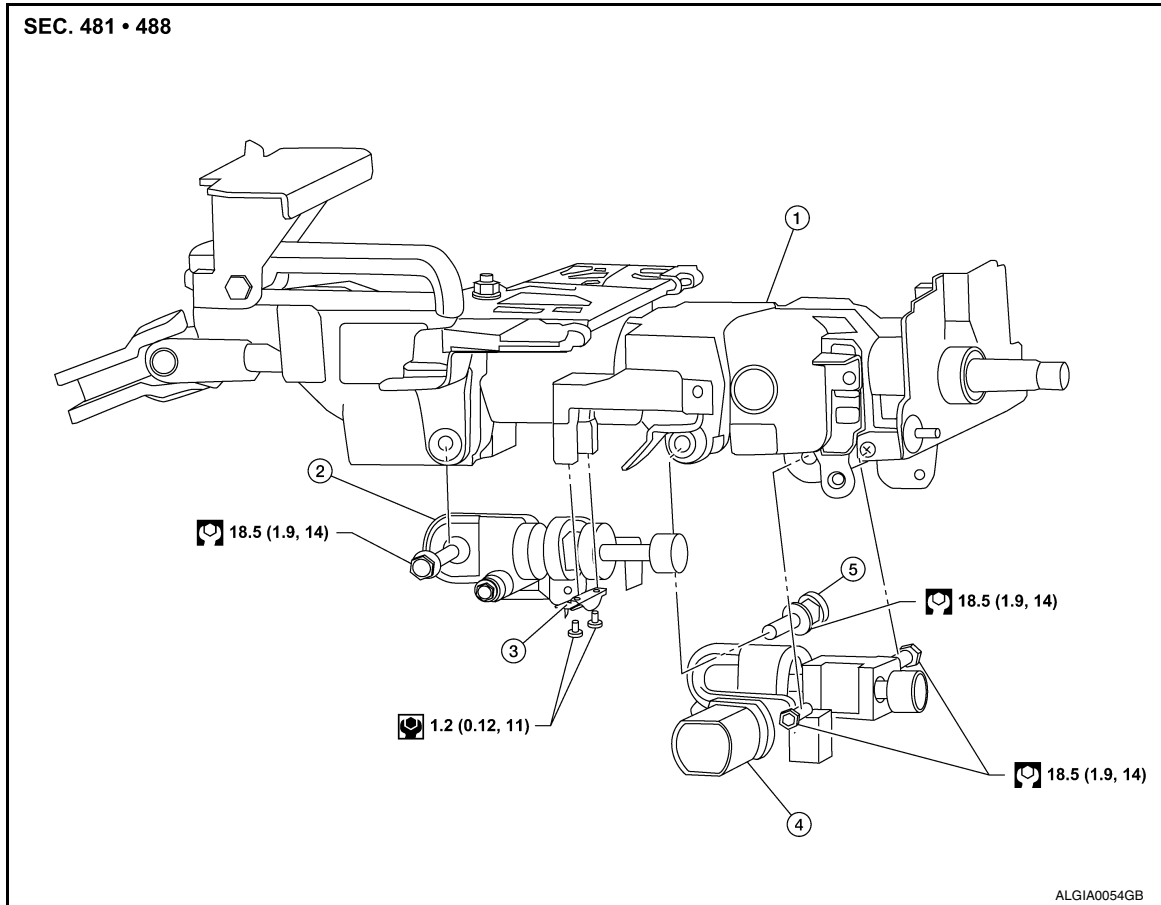

- | | | |
|-----------------------------|------------------------|---------------------------------|
| 1. Steering column assembly | 2. Telescope motor | 3. Telescope motor link bracket |
| 4. Tilt motor | 5. Tilt motor bolt cap | |

DISASSEMBLY

1. Remove the steering wheel. Refer to [ST-17. "Removal and Installation"](#).

Tilt motor

1. Remove the tilt motor as follows.
 1. Disconnect the harness connector (A) from the tilt motor.
 2. Remove the tilt motor link bolts (B).

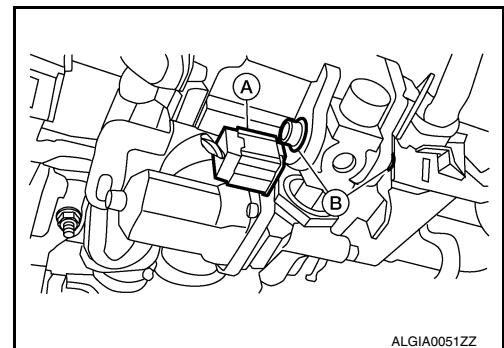

STEERING COLUMN

< UNIT DISASSEMBLY AND ASSEMBLY >

3. Remove the tilt motor bolt (A) from the RH side of column.
4. Remove the tilt motor (B).

NOTE:

If the steering wheel could not be tilted to the highest position, manually tilt steering wheel to the highest position.

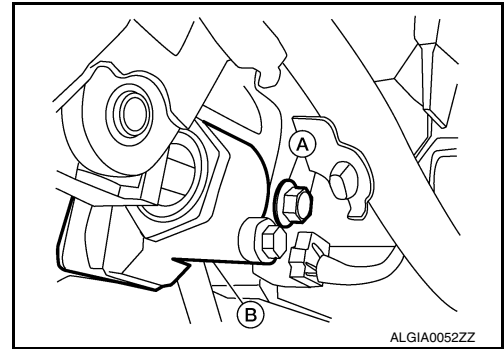

Telescope motor

1. Remove telescope motor as follows.
 1. Disconnect the harness connector (A) from the telescope motor.
 2. Remove the two telescope motor link screws (B) and telescope motor link bracket.
 3. Remove telescope motor bolt (C).
 4. Remove the telescope motor (D).

NOTE:

If the steering wheel could not be telescoped to full out position manually pull steering wheel to the full out position

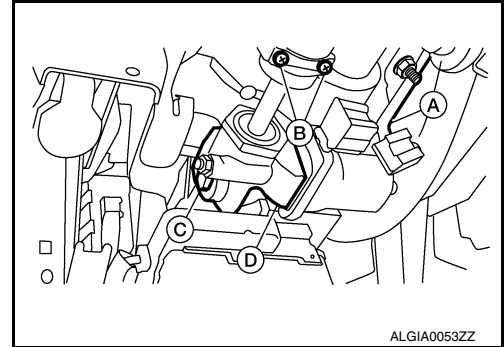

ASSEMBLY

Assembly is in the reverse order of removal

NOTE:

- Upon installation of the tilt motor link bolts manually move steering wheel up and down to align the bolts.
- Adjust the telescope motor link to full out position and adjust as needed to fit into proper installed position.
- Inform customer that they will need to reset their Automatic Drive Positioner (ADP) settings.

STEERING GEAR AND LINKAGE

< UNIT DISASSEMBLY AND ASSEMBLY >

STEERING GEAR AND LINKAGE

Exploded View

INFOID:000000009465787

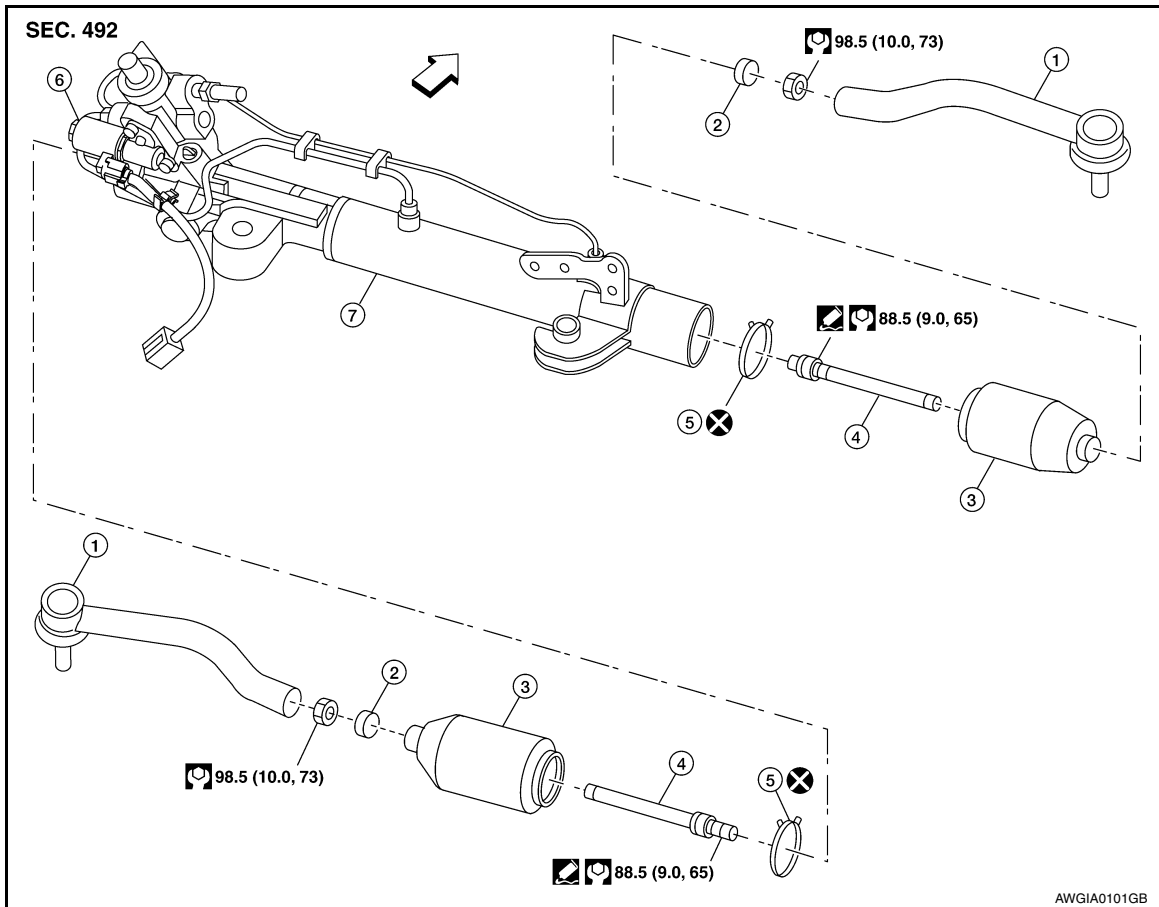

- | | | |
|------------------|---------------|---------------------------------------|
| 1. Outer socket | 2. Boot clamp | 3. Boot |
| 4. Inner socket | 5. Boot clamp | 6. SSPS valve (part of gear assembly) |
| 7. Gear assembly | ⇐ Front | ☑ Three Bond 1111B or equivalent |

Disassembly

INFOID:000000009465788

1. Remove outer socket locknut and outer socket.
2. Remove boot clamps and boot.
CAUTION:
Do not reuse boot clamps.
3. Remove inner socket.

Inspection

INFOID:000000009465789

INSPECTION AFTER DISASSEMBLY

Boot

Check boot for cracks. Replace if any damage is found.

Outer Socket and Inner Socket

- Ball joint swinging torque

STEERING GEAR AND LINKAGE

< UNIT DISASSEMBLY AND ASSEMBLY >

- Hook a spring balance to the ball stud and inner socket measuring point (*) and pull the spring balance. Make sure that the spring balance reads the specified value when ball stud and inner socket start to move. Replace outer socket and steering gear assembly if they are outside the standard.

Tool number : — (J-44372)

Swinging torque : Refer to [ST-38, "Steering Gear"](#)

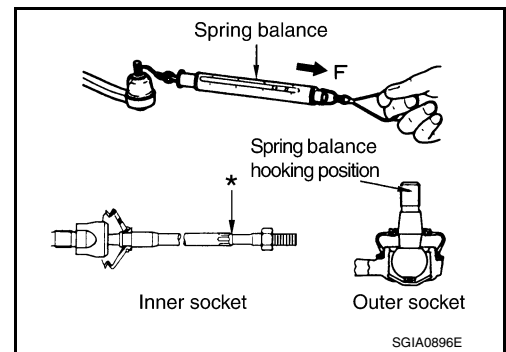

- Ball joint rotating torque
- Make sure that the reading is within the following specified range using Tool. Replace outer socket if the reading is outside the specified value.

Tool number : ST3127S000 (J-25765-A)

Rotating torque : Refer to [ST-38, "Steering Gear"](#)

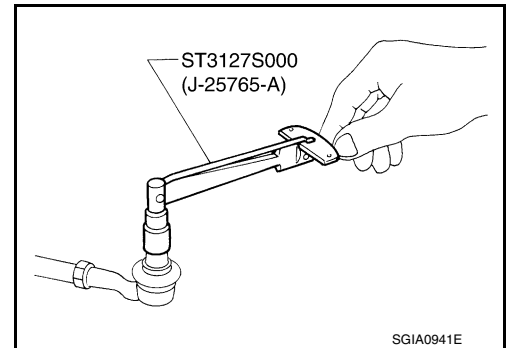

- Ball joint axial end play
- Apply an axial load of 490 N (50 kg, 111 lb) to ball stud. Measure amount of stud movement using a dial gauge and then make sure that the value is within the following specified range. Replace outer socket and inner socket if the measured value is outside the standard.

Axial end play : Refer to [ST-38, "Steering Gear"](#)

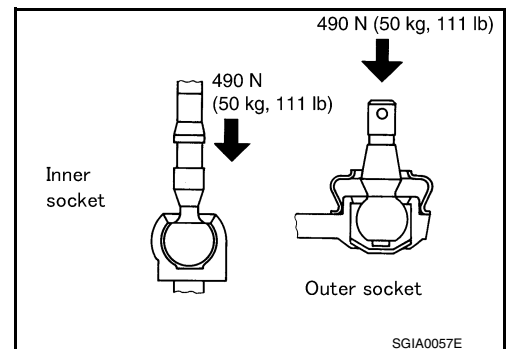

INFOID:000000009465790

Assembly

1. Apply Three Bond 1111B or equivalent to inner socket and turn pinion fully to retract inner socket into gear housing assembly.
2. Install large end (1) of boot (2) to gear housing assembly.
3. Install small end (3) of boot (2) to inner socket boot mounting groove.

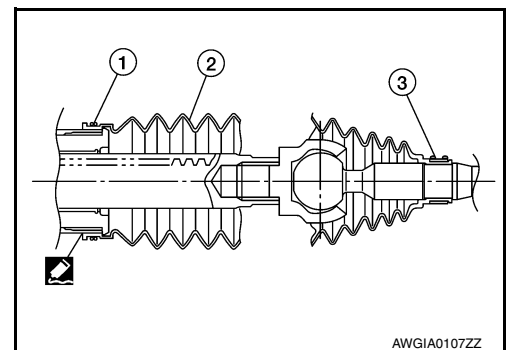

STEERING GEAR AND LINKAGE

< UNIT DISASSEMBLY AND ASSEMBLY >

4. Install boot clamp to boot small end.
CAUTION:
Do not reuse boot clamps.
5. Install boot clamp to boot large end using Tool.
CAUTION:
Do not reuse boot clamps.

Tool number : KV40107300 (—)

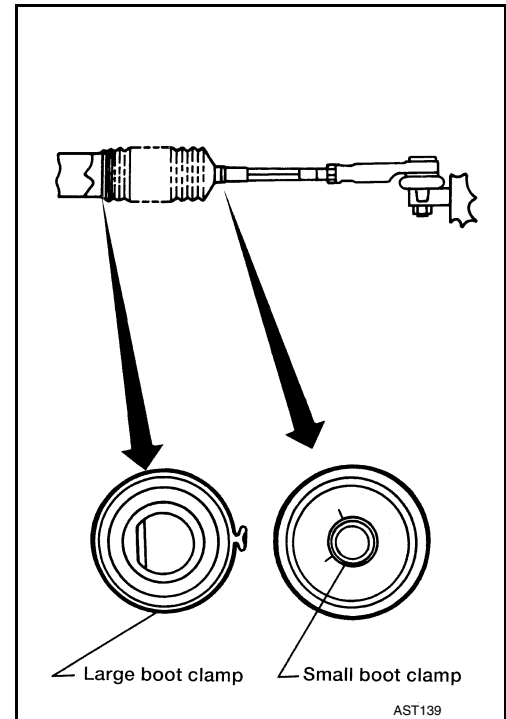

6. Adjust inner socket to standard length (L), and then tighten lock nut to the specified torque. Check length of inner socket (L) again after tightening lock nut. Make sure that the length is the standard.

Inner socket length (L) : Refer to [ST-38, "Steering Gear"](#)

CAUTION:
Adjust toe-in after this procedure. The length achieved after toe-in adjustment is not necessarily the above value.

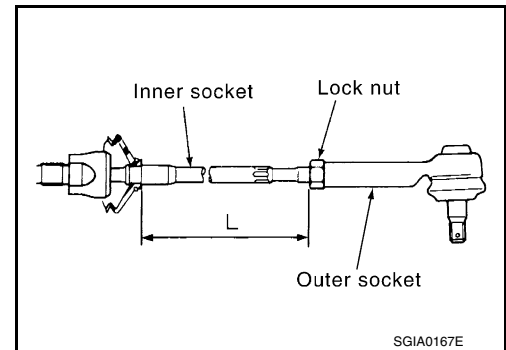

POWER STEERING OIL PUMP

< UNIT DISASSEMBLY AND ASSEMBLY >

POWER STEERING OIL PUMP

Disassembly and Assembly

INFOID:000000009465791

The power steering oil pump and pulley is not serviceable and should be replaced as an assembly. For front and rear bracket removal, refer to [ST-28, "Exploded View"](#).

SERVICE DATA AND SPECIFICATIONS (SDS)

< SERVICE DATA AND SPECIFICATIONS (SDS)

SERVICE DATA AND SPECIFICATIONS (SDS)

SERVICE DATA AND SPECIFICATIONS (SDS)

Steering Wheel

INFOID:000000009465792

Steering wheel axial end play	0 mm (0 in)
Steering wheel play	0 - 35 mm (0 - 1.38 in)
Steering wheel turning force	39 N (4 kg-f, 9 lb-f) or less

Steering Angle

INFOID:000000009465793

Unit: Degree minute (Decimal Degree)

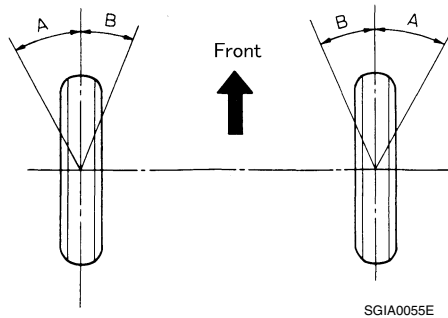

SGIA0055E

Tire size		P245/45R18	P245/40R19
Inner wheel angle (A)	Minimum	33° 30' (33.5°)	33° 30' (33.5°)
	Nominal	36° 30' (36.5°)	36° 30' (36.5°)
	Maximum	37° 30' (37.5°)	37° 30' (37.5°)
Outer wheel angle (B)	Nominal	31° 0' (31.0°)	31° 0' (31.0°)

Steering Column

INFOID:000000009465794

STEERING COLUMN LENGTH

Unit: mm (in)

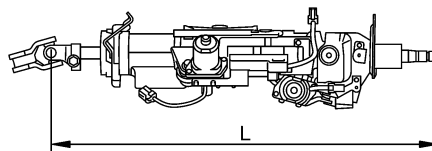

SGIA1177E

Steering column length (L)	Telescopic maximum	513 - 543 (20.20 - 21.38)
	Telescopic minimum	503 - 513 (19.80 - 20.20)

STEERING COLUMN ROTATING TORQUE

Unit: N·m (kg·m, in·lb)

Rotating torque	0 - 0.25 (0 - 0.03, 0 - 2)
-----------------	----------------------------

TILT MECHANISM OPERATING RANGE

SERVICE DATA AND SPECIFICATIONS (SDS)

< SERVICE DATA AND SPECIFICATIONS (SDS)

Unit: mm (in)

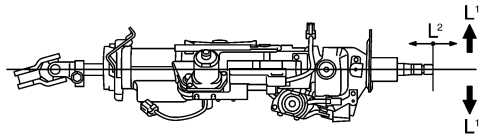

SGIA1179E

	Without electric motor	With electric motor
Tilt operating range (L ¹)	41 (1.61)	49.63 (1.95)
Telescopic operating range (L ²)	40 (1.57)	40 (1.57)

Steering Gear

INFOID:000000009465795

STEERING OUTER SOCKET AND INNER SOCKET

Steering gear type		PR26AF
Outer socket	Swinging torque	0.1 - 2.9 N·m (0.01 - 0.29 kg·m, 1.0 - 25 in·lb)
	<ul style="list-style-type: none"> • Measurement on spring balance • Measuring point: cotter pin hole of stud 	1.4 - 42.7 N (0.14 - 4.4 kg, 12 - 31 lb)
	Rotating torque	0.3 - 2.9 N·m (0.03 - 0.29 kg·m, 3.0 - 25 in·lb)
	Axial end play	0.5 mm (0.020 in) or less
Inner socket	Swinging torque	0.1 - 7.8 N·m (0.01 - 0.79 kg·m, 1.0 - 69 in·lb)
	<ul style="list-style-type: none"> • Measurement on spring balance • Measuring point at * mark shown 	0.8 - 64 N (0.082 - 6.5 kg, 0.18 - 14.4 lb)
	Axial end play	0.2 mm (0.008 in) or less
Inner socket length (L)		119.5 mm (4.705 in) or less

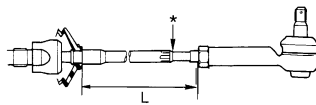

SGIA0950E

RACK STROKE

SERVICE DATA AND SPECIFICATIONS (SDS)

< SERVICE DATA AND SPECIFICATIONS (SDS)

Steering gear model	PR26AF	
Tire size	P245/45R18	P245/40R19
Rack stroke in neutral position (L)	69.5 ± 0.75 mm (2.735 ± 0.030 in)	

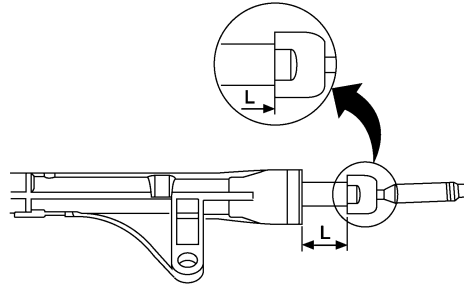

AWGIA0003GB

RACK SLIDING FORCE

Standard	301 ± 49 N (30.7 ± 5 kg-f, 67.7 ± 11 lb-f)
Minimum	210 N (21.4 kg-f, 47.2 lb-f)

Oil Pump

INFOID:000000009465796

Relief oil pressure at 1,000 rpm	9,800 + 500/ - 300 kPa (99.96 + 5.10/ - 3.06 kg/cm ² , 1,421.0 + 72.5/ - 43.5 psi)
----------------------------------	---

Steering Fluid

INFOID:000000009465797

Fluid type and capacity	Refer to MA-15. "FOR USA AND CANADA : Fluids and Lubricants" (United States and Canada), MA-16. "FOR MEXICO : Fluids and Lubricants" (Mexico).
-------------------------	--